

# Wireless Multi-Channel Sensor for Neurodynamic Studies

C. Chestek, P. Samsukha, M. Tabib-Azar, R. Harrison, H. Chiel, S. Garverick

Dept of EECS, Case Western Reserve University, U.S.A., cac31@case.edu

Dept of EECS, Case Western Reserve University, U.S.A., pxs118@case.edu

Dept of EECS, Case Western Reserve University, U.S.A., mxt7@case.edu

Dept of ECE and Bioengineering, University of Utah, U.S.A., harrison@ece.utah.edu

Depts of Biology, Biomedical Engineering and Neuroscience, Case Western Reserve University, U.S.A., hjc@case.edu

Dept of EECS, Case Western Reserve University, U.S.A., slg9@case.edu

## Abstract

This paper presents the design of a bio-compatible, implantable neural recording device for *Aplysia californica*, a common sea slug. Low-voltage extracellular neural signals ( $<100 \mu\text{V}$ ) are recorded using a high-performance, low-power, low-noise preamplifier that is integrated with programmable data acquisition and control, and FSK telemetry that provides 5-kbps wireless neural data through 18 cm of saltwater. The telemetry utilizes an 8-cm electric dipole antenna matched to  $50 \Omega$  by exposing the ends of the antenna to the saltwater. A 3-V lithium ion battery (160 mAh) allows 16 hours of recording. Neural data obtained using extracellular nerve electrodes and a wired interface to this device have  $2.5\text{-}\mu\text{V}_{\text{rms}}$  noise, comparable to commercial neural recording equipment.

## Keywords

Implantable, data acquisition, telemetry, low-power circuits, low-noise amplifier.

## INTRODUCTION

Nervous systems of marine animals, particularly invertebrates, have served as model systems for studying the neural basis of learning and memory. [1] They provide a tractable system in which a large percentage of the total neuron pool can be recorded from simultaneously. In addition to scientific benefits, implantable units designed for discrete invertebrate ganglia might have clinical applications in humans, particularly in the control of discrete ganglia in the autonomic nervous system. [2]

This paper presents a bio-compatible, implantable, neural recording unit for use in *Aplysia californica*, which can transmit neural data wirelessly from within a freely behaving animal in an aquarium environment. Similar implantable recording units have been designed that incorporate a high-gain differential amplifier for neural signals and a wireless telemetry link from a saltwater environment. [3-5] The design presented here builds on this configuration by adding a microcontroller with integrated A/D conversion to digitize neural signals close to the source, with a consequent reduction in noise to  $2.8 \mu\text{V}_{\text{rms}}$ . Large scale multi-channel wireless devices have been designed for cortical recordings in vertebrates by Wise et al, 2004 at the University of Michigan. [6] The integrated probes for these devices are long, sharp electrodes that penetrate into the brain

tissue. This probe geometry would be difficult to use with discrete ganglia, such as those found in invertebrates or the human autonomic nervous system. Also, in these special applications, the antenna cannot be placed close to the external air interface. The unit described here is designed specifically for discrete ganglia deep within a saltwater medium.

This paper discusses the design and implementation of this unit and provides preliminary neural data. The performance of this miniature unit is comparable to conventional laboratory equipment for neural signal acquisition. The basic approach can be scaled to produce an implantable wireless data acquisition unit for large-scale invertebrate studies.

## SYSTEM ARCHITECTURE

This implantable unit is custom designed for neural recording in freely behaving *Aplysia californica* sea slugs in a salt water environment. For live recordings, the input signal is obtained from an implanted stainless steel wire glued to a nerve or above a particular neuron on the ganglion. The neural action potentials themselves range from  $10\text{-}300 \mu\text{V}$  in amplitude with frequency content primarily between  $100\text{-}500\text{Hz}$ , with a small contribution from the firing frequency which may be  $0.5\text{-}100 \text{Hz}$ . In addition to  $60\text{-Hz}$  interference, the low frequency noise is particularly challenging since saltwater electrodes are associated with very large voltage drift on the order of a few Volts.

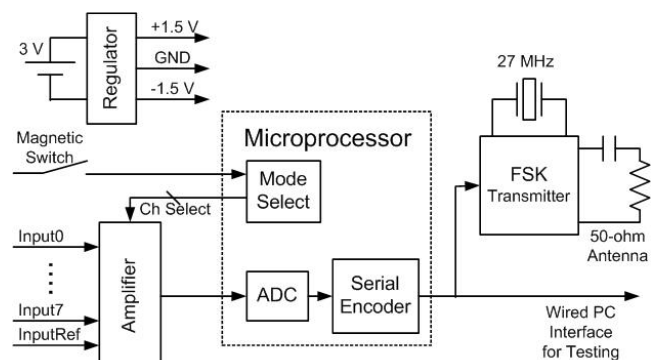

Figure 1. Overall Block Diagram

Figure 1 is an overall block diagram of this implantable sensor. The input electrodes attach to a high-gain differential amplifier with a bandpass filter. The single-ended output of this amplifier is digitized using an 8-bit microcon-

troller, which arranges the 8-bit data into a serial stream. Channels can be selected from outside of the animal using a magnetic switch. The PIC sends this data either directly to the PC through a wired RS-232 interface, or to a commercially available FSK transmitter. It is then transmitted out of the animal using an electric dipole antenna which can be implanted along the length of the animal's foot. The receiving antenna must be located inside the aquarium.

### PRELIMINARY EXPERIMENTS

Saltwater severely attenuates wireless signals, and several preliminary experiments were conducted to determine the feasibility of a saltwater telemetry system. Using a fifteen-gallon aquarium, several antenna configurations were evaluated using a commercially available 1-mW, 27-MHz transmitter as a source, and a spectrum analyzer to measure the signal strength at the receiving antenna. While there was severe attenuation, the signal could be detected up to 18 cm away. An electric dipole antenna with ends exposed had comparable performance to a magnetic loop antenna of comparable size. (See Figure 2.) Magnetic loop antennae are commonly used in implantable devices [7], but in this application, the long thin electric dipole antenna can be easily implanted through a small incision into the open space in a sea slug's foot.

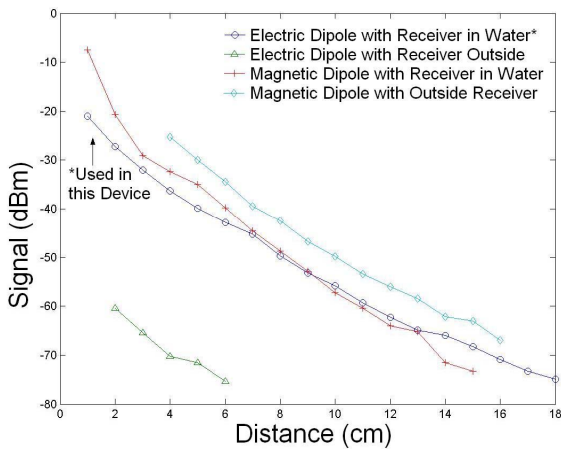

Figure 2. Antenna Performance Comparison

Animals were tested and found to tolerate unit implantation. On one occasion, we implanted the transmitter (encapsulated in Silicone glue) into a 400-g animal and verified that the signal strength observed at the receiving antenna matched the data shown above. The animal ate and behaved normally after the implantation. On another occasion, we implanted a blank PCB of equal size to our prototype (including the battery) using similar encapsulation. That animal also behaved normally. The received wireless signal strength was the same as for the tests in saltwater.

## DETAILED DESIGN

### Bioamplifier

The extracellular electrodes attach directly to the differential inputs of a custom bioamplifier IC, having core circuits that are described in [8]. It is designed for a first-stage gain of 100, with C1 set to 20 pF and C2 set to 200 fF. The gain of the second stage was set to 39 using external resistors, with R2=390 kΩ and R1=10kΩ. Due to the very large, low-frequency voltage drift associated with saltwater, it was necessary to use a highpass filter in the second stage. With C3 set to 1 μF, the highpass and lowpass cutoff frequencies of the overall frequency response are 100 Hz and 7 kHz respectively, for which the previously reported input-referred noise is 2.2 μV<sub>rms</sub>. Each of 8 first-stage amplifiers can be selected with a multiplexer, which has three associated control lines set by the microcontroller. (See Figure 3.)

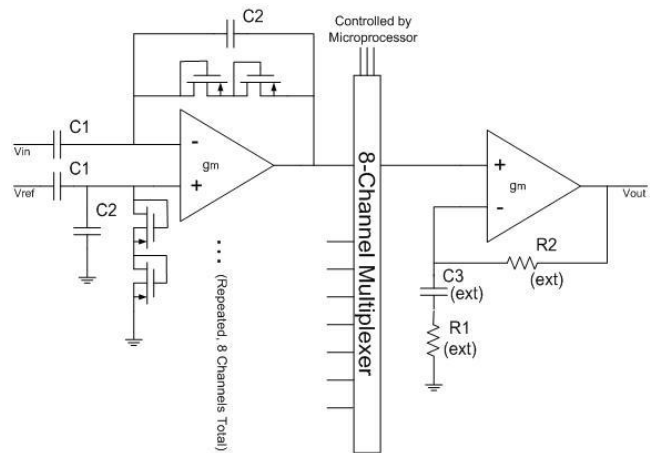

Figure 3. Schematic of Bioamplifier

### Microcontroller

For the microcontroller, we chose the PIC18F1320. This unit is low-power (450 uW,) compact, and inexpensive. It includes a built-in 8-bit A/D converter and RS-232 port. The microcontroller operates three parallel processes: data sampling and conversion, data transmission, and channel selection.

### Wireless Link

For the wireless transmitter, we chose a commercially available device, the Tricome T86. It modulates the digital data using frequency-shift keying (FSK) with a central frequency of 27-MHz, an FCC-approved frequency for applications having a relatively low carrier frequency and wide bandwidth (320 KHz). The relatively low carrier frequency has less attenuation in salt water than higher frequencies, and the large bandwidth will permit FSK bit rates up to 80 kbps in future work. The maximum throughput for the present device is 5 kbps.

The impedance of this antenna was measured with a network analyzer while stripping various amounts of insula-

tion from the ends of the wire, which was submerged in the aquarium. Using this technique and the dominantly resistive properties of saltwater, the antenna impedance was matched to the 50-ohm output of the T86 transmitter for maximum power efficiency.

### Testing Methods

In experiments that involved submerging the unit, the circuit board was covered with General Electric Silicone II glue and left to dry for 24 hours. If the unit was intended for implantation, it was cured in running water. The electrodes are similarly insulated up to the point of contact with the nerve.

The neural data shown in this paper was obtained with an *in vitro* preparation. The animal was anaesthetized with 50% of its body weight (mL/g) of  $MgCl_2$ . The feeding musculature was then dissected out and the buccal ganglion (responsible for controlling feeding behavior) was carefully removed from the muscles. This ganglion was pinned out in a Sylgard covered Petri dish. Buccal nerve 3 was suctioned into a thin polyethylene tube filled with saltwater and an Ag/AgCl wire was inserted into the solution. The end of this wire was attached to the input of our unit for testing.

## EXPERIMENTAL RESULTS

### Fabrication

The custom amplifier IC was fabricated in the AMI ABN 1.5- $\mu m$  two-metal two-poly CMOS process and packaged in an LCC28. Each of the 8 amplifier circuits uses 0.16  $mm^2$  of silicon area, and 67% of this area is taken up by capacitors. All the components discussed above were assembled on a double-sided PCB (See Figure 4.) measuring 1.2" x 0.6" powered by a 3-V, size 1/3N, 160 mAHr, Lithium ion battery. This unit can be continuously operated for 16 hours using the wireless interface, and 90 hours using a wired interface.

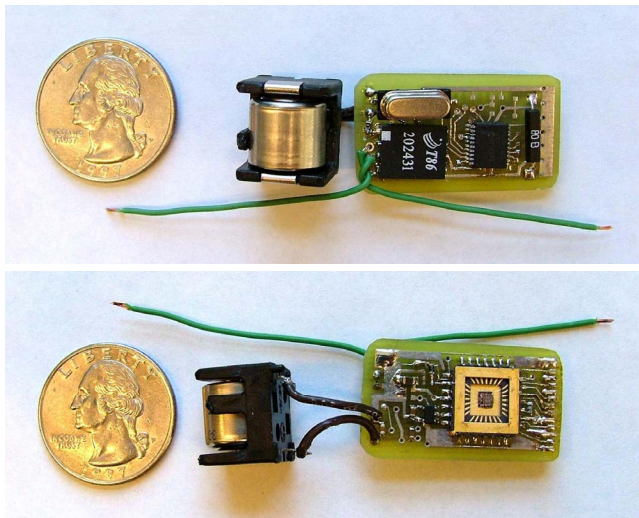

Figure 4. Photograph of Prototype Front and Back

### Noise Analysis

We tested the noise performance of this prototype inside a full Faraday cage used for neuroscience recordings. When using a wired interface, the unit was isolated using an opto-coupler to simulate wireless conditions. The measured gain was 3480. The amplifier itself has measured the noise of 2.5  $\mu V_{rms}$ , which is comparable to the 2.2  $\mu V_{rms}$  reported in [1]. The addition of the input wires, the microcontroller, and the transmitter did increase the noise slightly, to 2.8  $\mu V_{rms}$ . The frequency spectrum of the noise is shown in Figure 5, adequate for recording very small action potentials. The noise, however, increased dramatically when the electrodes were placed into a saltwater solution, particularly in the low frequency range. Even with the addition of a highpass filter on the second stage, the DC value tends to drift with an amplitude up to 260  $\mu V$ . High-frequency noise tended to vary significantly, from its base value of 2.8  $\mu V_{rms}$  to 4.1  $\mu V_{rms}$  presumably due to outside interference. The unit also began picking up ground artifacts that somewhat resembled “burst” noise.

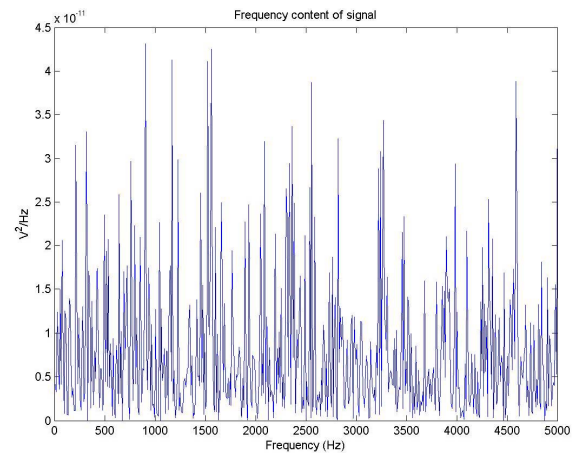
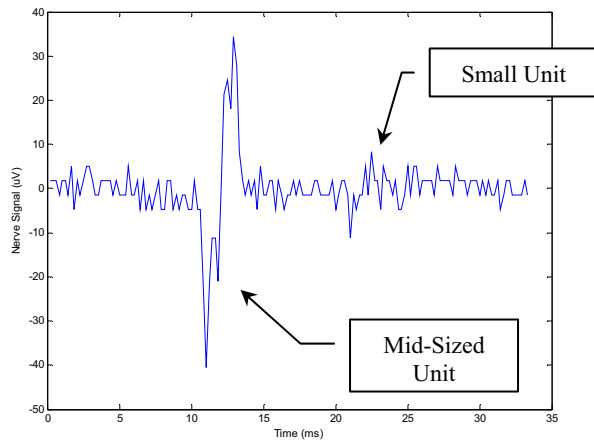

Figure 5. Frequency Content of Noise

### Neural Data

Despite the increased noise, we were consistently successful in measuring neural activity *in vitro*. Figure 6 shows an example of a mid-sized and small-sized action potential as recorded by the prototype. The quality of this data is comparable to commercial devices and the unit is convenient to use since it can be easily attached to a micro-manipulator. However, we would need to reduce the noise for live animal recordings, since the amplitude of *in vivo* signals tends to be lower. Since a high-pass filter is used at the input of the second stage, the offset difference between channels combined with the settling time at the second stage makes it difficult to scan through the channels quickly. In future versions of this system, we will either raise the cutoff frequency of the first stage, or add a dedicated second-stage amplifier to each channel to facilitate a scanning mode.



**Figure 6. In Vitro Neural Data**

### Wireless Performance

The commercial transmitter successfully modulates the digital data with a bandwidth of 6.6 kHz and a central frequency of 27.1305 MHz. The signal strength was measured at a distance up to 18 cm with the unit implanted inside of the animal. While this unit only allows for one channel of transmission, it provides proof of concept for a future custom FSK transmitter with a larger bandwidth. Similarly, this unit's high power consumption (30 mW) is a limiting factor in this design, but the efficiency can be significantly improved in future custom designs. Work is in progress for a receiver that will be compatible with the current unit and the next generation transmitter that will be capable of an 80-kbps data rate, delivering a 1-mW signal with 80% efficiency.

### CONCLUSIONS

In its current state, this prototype can be used for neurodynamic studies of *Aplysia in vitro* preparations. Also, some preliminary testing has been done with freely behaving animals. Using what we have learned from this iteration, we have begun work on the next prototype. We will reduce the device size by fully integrating the electronics, and increase the high-pass cutoff frequency of the first stage amplifier to deal with the low frequency noise. For the wireless link, the power consumption of our custom-designed FSK transmitter will be dramatically lower than the commercially available device we used in this prototype. Also, the bandwidth will be raised to 80 kbps to allow a sufficient sampling rate for multiple channels. Test circuits for these modules are currently in fabrication.

Since the smaller, tractable, multi-neuron circuits found in invertebrates such as *Aplysia* resemble those used for VLSI neural network applications, multi-channel invertebrate studies could provide a wealth of information for this field. Also, due to the geometrical similarity of invertebrate ganglion to sympathetic ganglia located in the human central nervous system, interface devices designed for invertebrate systems could be used to restore function in humans.

### ACKNOWLEDGMENTS

We thank the National Science Foundation for their support of this research. (IBN-0218386 to H.J.C.) Also, we thank the NSF Graduate Research Fellowship program (ID: 2004016147 to C.C.)

### REFERENCES

- [1] E. Kandel, J. Schwartz, and T. Jessell, *Principles of Neural Science*, 4<sup>th</sup> ed., McGraw-Hill, New York, NY (2000).
- [2] A. Guyton, and J. Hall, *Textbook of Medical Physiology*, 10<sup>th</sup> ed., W. B. Saunders, Philadelphia, PA (2000).
- [3] P. Irazoqui-Pastor, I. Mody, and J. Judy, "In-Vivo EEG Recording Using a Wireless Implantable Neural Transceiver," 1st Inter. IEEE EMBS Conf. on Neural Engineering, Capri Island, Italy, p.20-22, March 20-22 (2003).
- [4] G. DeMichele, and P. Troyke, "Integrated Multi-Channel Wireless Biotelemetry System," 25<sup>th</sup> Inter. Conf. of the IEEE EMBS, Cancun, Mexico, vol. 4, p. 3372-3375, Sept. 17-21 (2003).
- [5] S. Takeuchi, and I. Shimoyama, "A radio-telemetry system with a shape memory alloy microelectrode for neural recording of freely moving insects," IEEE Trans. on Biomedical Engineering, vol 51, nr. 1, p. 133-137, January 2004.
- [6] K. Wise, D. Anderson, J. Hetke, D. Kipke, and K. Najafi, "Wireless implantable Microsystems: high-density electronic interfaces to the nervous system," Proc. of the IEEE, vol. 92, nr. 1, p. 76-97, January 2004.
- [7] P. Troyke, and M. Edgington, "Inductive links and drivers for remotely-powered telemetry systems," Antennas and Propagation Society Inter. Symp., vol. 1, p. 60-62, July 2000.
- [8] R. Harrison, and C. Charles, "A Low-Power Low-Noise CMOS Amplifier for Neural Recording Applications," IEEE J. of Solid-State Circuits, vol. 38, nr. 6, p. 958-965, June 2003.